

MITSUBISHI

Mitsubishi Electric Corporation **Industrial** Robot

BFP-A6079-0075E

MELFA Technical News

February 2013

Subject: Report of addition of the plate for tooling cable in RH-3/6FH**Applicable to:** RH-3/6FH series

Thank you for your continued support of Mitsubishi industrial robot "MELFA".
This Technical news explain the addition of the plate for tooling cable in RH-3/6FH.

1. Model and added part

- (1) Model : RH-3/6FH series
(2) Added part name : The plate for tooling cable

As figure shows, the plate for tooling cable is added in the No2 arm upper cover. Tooling cable or air tube that is put through spline shaft can be put along this plate.

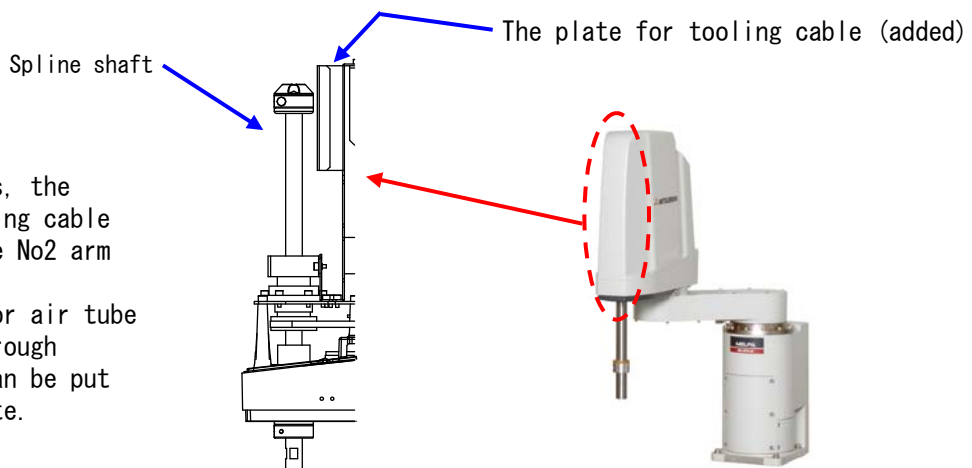

RH-3/6FH series

「No2 arm (end of arm)」

(*) This figure shows RH-3FH type.

With this addition, the plate that was attached to the option "Internal Wiring/Piping set for hand (the following items)" has not been attached. (This plate is same as added plate.)

- 1F-HS408S-01 (RH-6FH 200mm stroke)
- 1F-HS408S-02 (RH-6FH 340mm stroke)
- 1F-HS304S-01 (RH-3FH)

2. Reason for change

Tooling convenient means

Installing the plate for tooling cables reduces the procedures of tooling tasks, such as designing, arranging plate.

3. Time of change

July, 2012

(*) The robot produced before above hasn't been attached with the plate.

If you need the plate, please contact Nagoya Works.

MITSUBISHI ELECTRIC CORPORATION