

TECHNICAL BULLETIN

[Issue No.] T12-0014

[Page] 1/6

[Title] A1SD75M□/AD75M□ Additional Functions

[Date of Issue] Feb, '03

[Relevant Models] A1SD75M1, A1SD75M2, A1SD75M3, AD75M1, AD75M2 and AD75M3

Thank you for your continued support of Mitsubishi programmable logic controllers, MELSEC-A series.

This bulletin provides information for the functions that have been added to the A1SD75M□/AD75M□.

1. Additional functions

- (1) Absolute position restoration mode switching function
- (2) Encoder output pulse function and slight vibration suppression function, used with MR-J2S-□B servo amplifier

2. Applicable models

Applicable models and versions are shown below.

The version specifications must be satisfied for both the software and hardware.

Model name	Hardware version	Software version
A1SD75M1	G or later	W or later
A1SD75M2	G or later	
A1SD75M3	H or later	
AD75M1	F or later	
AD75M2	F or later	
AD75M3	G or later	

The module software and hardware versions can be checked as follows.

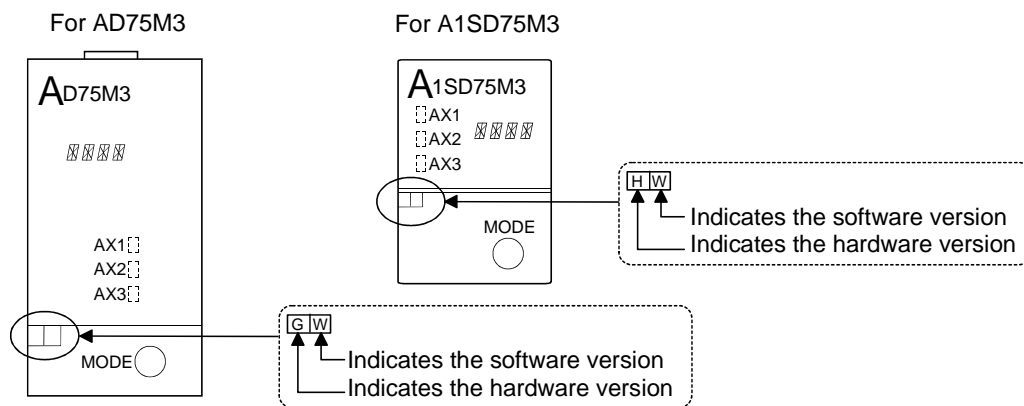

3. Function details

This section describes the details of each function.

3.1 Absolute position restoration mode switching function

This function switched the mode for the absolute position restoration. Selecting the infinite length mode enables absolute position detection of a one-way-rotating object outside of the range of 360 degrees and it is useful for control using a turntable.

The function is available only when the unit setting parameter is set to “degree”.

3.1.1 Specifications

The absolute position restoration function can be selected from 2 modes (absolute position restoration range), in the absolute position detection system. This is applicable when the unit setting parameter is set to “degree”.

(1) Standard mode (Conventional mode)

The absolute position restoration is only applicable within the range of 360 degrees from the zero return position (The current feed value changes within the range from 359.9999° to 0° or 0° to 359.9999° degrees).

(2) Infinite length mode (Additional mode)

The absolute position restoration is available outside the range of 360 degrees from the zero return position (The current feed value changes exceeding the range from 359.9999° to 0° or 0° to 359.9999° degrees).

Available range for the absolute position detection system (Unit: Degree)

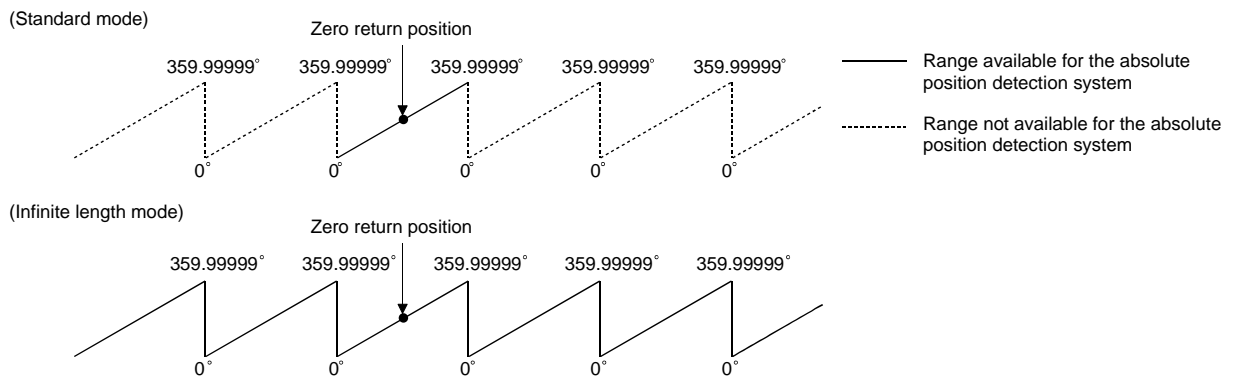

Fig. 3.1 Available range for the absolute position detection system when unit setting parameter is set to “degree”

To set absolute position restoration mode, set the option in “Pr.59: Absolute position restoration selection” from the Zero point return detailed parameter, and then initiate zero point return for the machine.

The selected mode can be confirmed by “Absolute position restoration mode” from the axis monitor.

After the system is powered on, the machine starts in the mode determined by the machine zero return and restores the absolute position.

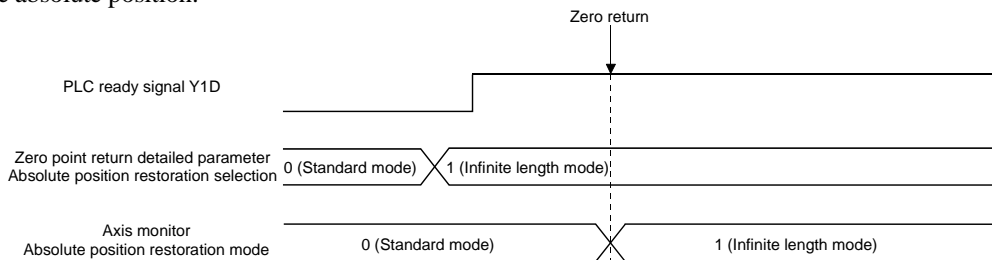

Fig. 3.2 Timing diagram for absolute position restoration mode setting

In the infinite length mode, the A1SD75M□ /AD75M□ automatically updates the absolute position data stored in FeRAM every time the position moves by a fixed distance (*1), and detects the absolute position for the infinite length positioning.

The axis monitor “FeRAM access counts” increases in increments of 2 when updating automatically.

*1: The fixed distance is determined by the value set in the basic parameters 1 “Pr.2: No. of pulses per rotation (Ap)”.

TECHNICAL BULLETIN

[Issue No.] T12-0014

[Page] 3/6

[Title] A1SD75M□/AD75M□ Additional Functions

[Date of Issue] Feb, '03

[Relevant Models] A1SD75M1, A1SD75M2, A1SD75M3, AD75M1, AD75M2 and AD75M3

3.1.2 Additional buffer memory addresses

(1) Zero point return detailed parameter

This parameter can be set in the sequence program or by GX Configurator-AP (Version1.12N or later).

Parameter No.	Item	Description	Buffer memory address		
			Axis 1	Axis 2	Axis 3
Pr. 59	Absolute position restoration selection	Selects the desired mode for the absolute position restoration in the absolute position detection system, when the unit setting parameter is set to “degree”. The function is activated after machine zero return is completed.	91	241	391
		0: Standard mode (Initial value set to factory default = 0) 1: Infinite length mode			

The setting is updated when the PLC ready signal (Y1D) turns ON from OFF. Turn this signal (Y1D) OFF and then ON when the set value has been changed.

(2) Axis monitor

Buffer memory address			Item	Description	Initial value set at factory
879	979	1079			
				0: Standard mode 1: Infinite length mode	

3.1.3 Additional error code

Division of error	Error code	Name of error	Description	Operation status when error occurs	Corrective action
Parameter	998	Absolute position restoration selection error	The zero return detailed parameter “Absolute position restoration selection” is set to “1: Infinite length mode” when the hardware version does not support the absolute position restoration switching mode.	AD75 ready signal (X0) does not turn OFF.	Select “0: Standard mode” and turn ON the PLC ready signal (Y1D) from OFF.

TECHNICAL BULLETIN

[Issue No.] T12-0014

[Page] 4/6

[Title] A1SD75M□/AD75M□ Additional Functions

[Date of Issue] Feb, '03

[Relevant Models] A1SD75M1, A1SD75M2, A1SD75M3, AD75M1, AD75M2 and AD75M3

3.1.4 Additional warning codes

Division of warning	Warning code	Name of warning	Description	Operation status when warning occurs	Corrective action
Common	11	Excessive automatic update	In the infinite length positioning control set in the unit setting parameter of "degree", the number of access times to FeRAM exceeds 9.9999×10^9 .	Operation is continued.	Replace the module.
	12	Automatic update failure	Writing to FeRAM for automatic update of the absolute zero position is not completed normally, when the infinite length positioning control set in the unit setting parameter of "degree".	Operation is continued.	Replace the module.

3.1.5 Precautions when using infinite length mode for the absolute position detection system

- (1) For changing to infinite length mode in the absolute position restoration mode, please follow the notes below.
 - (a) Set the basic parameters 1 "Unit setting" to "2: degree".
 - (b) Set the detailed parameters 1, "Software stroke limit setting" to "Invalid".
 - (c) Set the servo basic parameter "Amplifier setting" to "1: Absolute position detection enabled".
 - (d) Perform machine zero return.

If any of the above conditions are not satisfied, the absolute position restoration mode is switched back to the standard mode upon completion of the machine zero return.
- (2) "Machine feed value" of the axis monitor is not usable.
- (3) The following control methods are not available.
 - (a) "1-axis fixed-feed control"
 - (b) "2-axis fixed-feed control"
 - (c) "Speed-position change control (Forward)"
 - (d) "Speed-position change control (Reverse)"
 - (e) "Current value change"

If any of the above methods are executed, the following error will occur "Control method error: Error code 524".
- (4) The following positioning start is not available.
 - (a) "High-speed zero point return (Start No. 9002)"
 - (b) "Current value change (Start No.9003)"

If any of the above methods are executed, the following error will occur "Out of start No. range: Error code 543".
- (5) To use the control method, "Speed control (Forward)" or "Speed control (Reverse)", set the detailed parameters 1 "Current feed value during speed control" to "1: Update current feed value".
Setting a value other than "1" will result in the following error "Control method setting error: Error code 524".
- (6) If the servo motor axis has made 15000 rotations or more while the communication between the AD75 and the servo amplifier has stopped due to power-OFF, the absolute position restoration may not be normally executed the next time the system is powered back ON. If this situation is caused from an external source, use a servomotor included with a brake so the motor axis is fixed, in order to prevent this from occurring.

TECHNICAL BULLETIN

[Issue No.] T12-0014

[Page] 5/6

[Title] A1SD75M□/AD75M□ Additional Functions

[Date of Issue] Feb, '03

[Relevant Models] A1SD75M1, A1SD75M2, A1SD75M3, AD75M1, AD75M2 and AD75M3

- (7) When the following parameters are changed, perform zero return again after machine zero return is completed. Otherwise the absolute position restoration does not work correctly.
- (a) Basic parameters 1
Unit setting, No. of pulses per rotation, Movement amount per rotation, Unit magnification
 - (b) Detailed parameters 1
Software stroke limit upper limit value, Software stroke limit lower limit value
 - (c) Zero point return basic parameters
Zero point address
 - (d) Zero point return detailed parameters
Absolute position restoration selection
 - (e) Servo basic parameters (*2)
Amplifier setting, Direction of rotation
- *2: When having changed the servo basic parameters shown above in (e) after starting communication between the AD75 and the servo amplifier, turn OFF either of them and then ON to restart communication between them.
- (8) When setting to “1: Infinite length mode” for both the absolute position restoration mode and the absolute position restoration selection, and then toggling the PLC ready signal (Y1D) from OFF to ON, it will result in an error being generated.
- (a) Setting the unit setting parameter to other than “2: degree”
“Out of unit setting range: Error code 900”
 - (b) Setting the software stroke limit function to “Valid”
“Upper software stroke limit: Error code 921”, “Lower software stroke limit: Error code 922”
- (9) Every time machine zero return is executed, the FeRAM access count increases as follows:
- (a) When the absolute position restoration mode is switched between “Standard mode” and “Infinite length mode”
The FeRAM access count increases by 4.
 - (b) When the absolute position restoration mode is not switched
The FeRAM access count increases by 2.
- (10) When the FeRAM access count reaches 9.999×10^9 or more at the time of absolute zero position automatic update, the warning “Excessive automatic update: Warning code 11” is shown.
- (11) When writing to FeRAM is not completed at the time of absolute zero position automatic update, the warning “Failed in automatic update: Warning code 12” is shown.

TECHNICAL BULLETIN

[Issue No.] T12-0014

[Page] 6/6

[Title] A1SD75M□/AD75M□ Additional Functions

[Date of Issue] Feb, '03

[Relevant Models] A1SD75M1, A1SD75M2, A1SD75M3, AD75M1, AD75M2 and AD75M3

3.2 Encoder output pulse function and slight vibration suppression function, used with MR-J2S-□B

Encoder output pulse function and the slight vibration suppression function for the servo amplifier are supported by the A1SD75M/AD75M, when used with the MR-J2S-□B.

3.2.1 Functions

(1) Encoder output pulse function

The following 2 setting methods are available.

- Output pulse number setting: Sets the number of the encoder's output pulses per servo motor rotation.
- Dividing ratio setting : Sets the dividing ratio of the number of MR-J2S-□B servo motor pulses to the number of encoder pulses (131072 pulses/rotation).

(2) Slight vibration suppression function

The slight vibration suppression function can be set to "Enable" or "Disable".

3.2.2 Parameter setting

The relevant A1SD75M/AD75M servo parameters corresponding to the applicable functions are shown below.

For details on the servo parameter, Pr. 124, 133 and 138, refer to the relevant MR-J2S-□B servo amplifier instruction manual.

Servo parameter No.	Item	Description	Buffer memory address		
			Axis 1	Axis 2	Axis 3
Pr. 124	Optional function 2	Slight vibration suppression selection <input type="checkbox"/> <input type="checkbox"/> 0 □ H: Invalid (Initial value) <input type="checkbox"/> <input type="checkbox"/> 1 □ H: Valid	124	274	424
Pr. 133 (*3)	Optional function 6	Encoder pulse output selection <input type="checkbox"/> 0 □ □ H: Number of pulses (Initial value) <input type="checkbox"/> 1 □ □ H: Dividing ratio	133	283	433
PR. 138 (*3)	Encoder output pulse	0 to 65535 (Initial value: 4000 pulses)	138	288	438
PR. 149 (*3)	Servo parameter transmission setting	0: When using other than MR-J2S-□B (Initial value) F003H: When using MR-J2S-□B	149	299	449

Setting "F003H" to Pr.149 enables setting of Pr. 124, 133 and 138 shown in the above table.

*3: This parameter cannot be set with GX Configurator-AP. Set this from the sequence program.